

**P4, P5, EP5, APEX 7000  
Pneumatic Positioners**

FCD PMENIM0006-00-A5 12/18

**Installation  
Operation  
Maintenance**



# Contents

---

1. Introduction	4
2. Storage instructions	6
3. Function	8
4. Installation	9
5. Connections	10
6. Cam adjustment	12
7. Calibration	13
8. Indicator adjustment	14
9. Front cover and indicator cover	14
10. I/P Unit (EP5/APEX 7000)	15
11. How to mount the I/P Unit to the positioner unit (P5/EP5)	16
12. Maintenance	17
13. Feedback unit (P5 or EP5)	22
14. Trouble shooting	23
15. Technical data	24
16. Spare parts	27
Appendix A	33



**Warning!**

*Special Conditions for Safe Use*

The enclosure is made of aluminum and impact or friction caused by external objects shall be avoided in the application.

Rubbing of the windows with dry fabrics shall be avoided when the positioner is used in an IIC atmosphere in order to avoid potentially incensive static discharges.

The ambient temperature range for the positioner is  $-20^{\circ}\text{C} < T_a < 85^{\circ}\text{C}$

The I/P converter has to be installed in an enclosure that satisfies the following clauses:

Complies with "electrostatic charge" requirements in EN 60079-0, clause 7.4

A suitable degree of protection minimum IP20 according to 6.1 in EN 60079-11

Shall not contain by mass, more than, 7.5% in total of magnesium according to clause 8.1 in EN 60079-0

According to descriptive document: IP-653.

Shall withstand dielectric strength test with 500V AC for 1 minute according 6.3.12 in EN 60079-11.

# 1. Introduction

---

## P4

The P4 is a pneumatic valve positioner for double acting actuators, rotary or linear. It can also be used for single acting applications by simply plugging one of the outlet ports, C1 or C2.

It features a standardized foot print, external zero adjustment, gold plated spool valve, positive internal pressure and a bright visible position indicator. The simple, sturdy design with few moving parts together with the well proven spool valve design provides long and trouble free operation. Together with the unit, a wide range of mounting kits are offered for quarter turn and linear applications.

Calibration and set up is quick and simple, all done by thumb wheels. The unit requires a minimum of maintenance and the only tool needed is a flat screw driver.

For installation of gauges T-connectors are required.

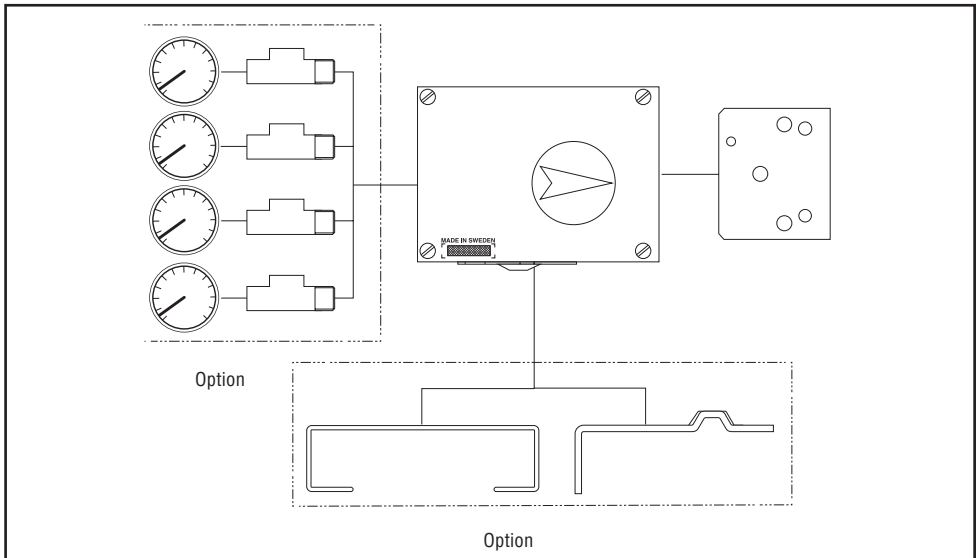

**P5**

The base unit of the system is the pneumatic positioner, used in either single or double acting applications. P5 comes standard with a high gain spool valve assembly, gauge ports and an O-ring sealed housing.

The modular design concept allows for easy addition of accessories such as I/P converter and/or a feedback package, both which are isolated from the basic pneumatic unit. These accessories can be factory or field mounted.

Ease of calibration and maintenance are built into to the design with easily accessible span and zero adjustment, and very simple parts replacement.

**EP5**

The EP5 has same features and benefits as the P5 positioner. It's modular to suit several applications, General applications, intrinsically safe, explosion proof and fail freeze versions are offered.

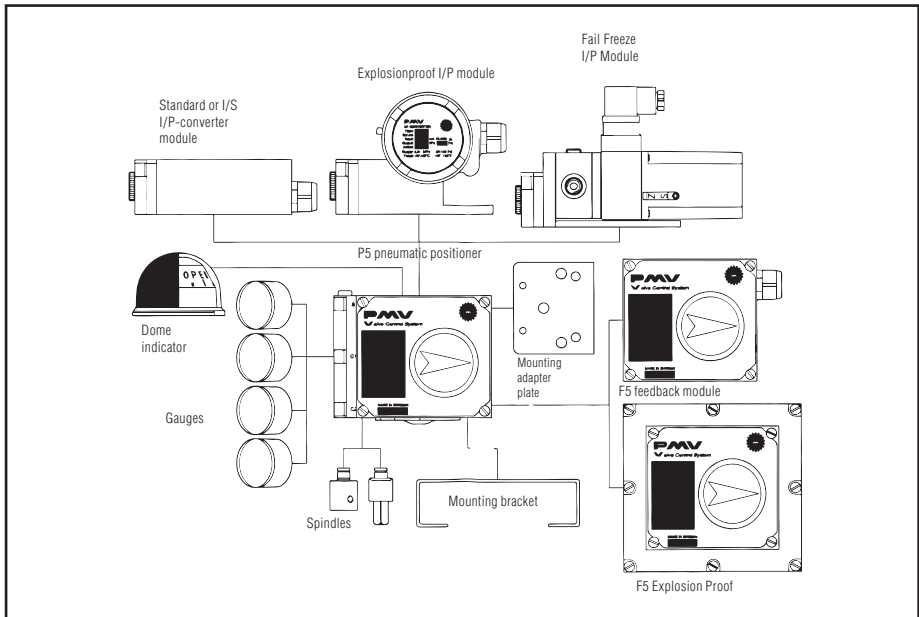

## 2. Storage instructions

---

### **PMV Positioner and feedback module storage and handling procedures**

PMV Positioners and feedback modules are precision instruments which should be stored and handled accordingly to avoid problems or damage.

Electro-pneumatic positioners/feedback modules contain electronic components which can be damaged by exposure to water. Appropriate precautions should be taken to protect units while in storage.

### **Warehouse storage**

Stored in original PMV shipping containers, units should be stored in an environmentally controlled area, i.e. clean, cool (15-26°C, 60-80°F) and dry, out of direct sunlight or weather exposure.

### **Field storage**

**Note:** Once the air supply to the positioner is connected and turned on, internal air bleed will prevent the ingress of moisture and protect the unit from corrosion. It is recommended that the air supply be left on at all times.

- If units are installed immediately, turn, and leave on, the air supply.
- If positioners must be stored outdoors, tighten all covers which may have loosened in shipment, make sure all open enclosure entry points are sealed.

Feedback modules should have cover tightened and conduits entries sealed. Positioners/Feedback modules should be wrapped and sealed air and watertight with desiccant inside the plastic, units should be securely covered with an opaque cover and not exposed to direct sunlight, rain or snow.

### **Pneumatic positioners**

Units should have all ports sealed and be protected from direct exposure to weather.

For long term storage (>1 month) or overseas shipment units should be protected with plastic and desiccant.

### **Potential damage mechanism**

When units are stored in hot, humid climates, the daily heating/cooling cycle will cause air to expand/contract and be drawn in and out of the positioner/feedback housing.

Dependent on the local temperature variations, humidity and dew points and time in storage condensation could occur and accumulate inside on the I/P Converter causing erratic operation or failure due to water and corrosion. The potential for condensation damage is especially high in southern climates and aggravated if units are exposed to direct sunlight.

**For further assistance, please contact you nearest PMV office.**

**Storage Seal (P5/EP5)**

P5/EP5 is supplied with all enclosure entry points sealed. The seal is only a storage seal, not to be used as seal when P5/EP5 is in operation. If Storage Seal is removed or damaged, make sure all open enclosure entry points are proper resealed before further shipping or storage.

Use circular stickers marked **I**, **S** and **OUT**, supplied on Storage Seal or vapour proof tape.

**P5**

Remove Storage Seal from connection block, mount positioner on actuator/valve, make connections according to section 5, (Page 10). Calibrate span and Zero according to section 7, (Page 13).

Clean any oil/debris off the connecting block, then reseal open enclosure entry ports, use circular stickers marked **I**, **S** and **OUT**, supplied on Storage Seal or vapour proof tape.

**EP5**

Follow P5 instructions as above. Remove Storage Seal for conduit entry **I<sub>E</sub>**, connect input signal cable and install proper cable gland to secure the units sealing.

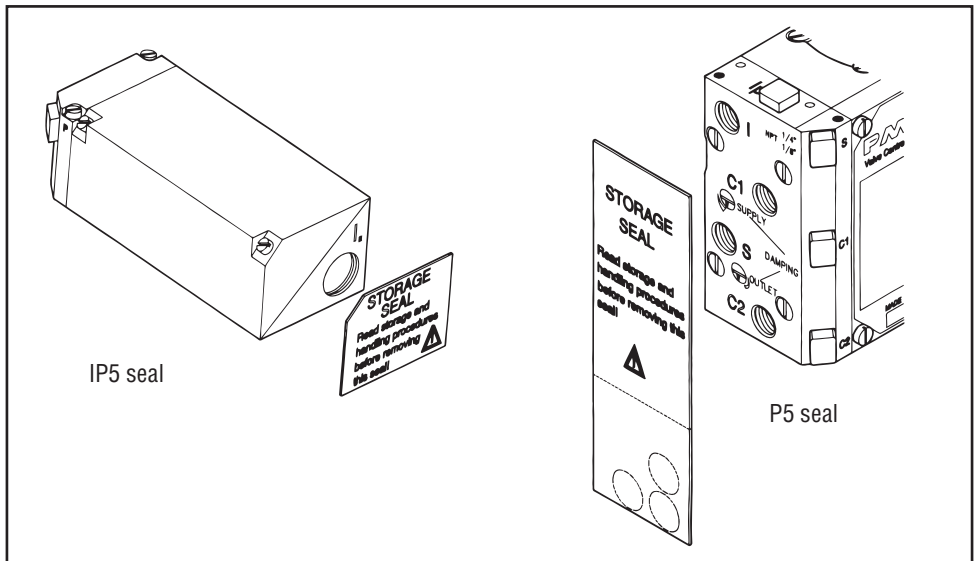

### 3. Function

The P4 and P5/EP5 operates on a force balance principal. Force is originated by the signal pressure transmitted through a diaphragm on to the balance arm. The opposing force is achieved through the feedback spring and is proportional to the position of the lower arm.

The lower arm position is determined by the position of the cam which is secured to the spindle and connected to the actuator shaft thus providing the feedback from the actuator/valve. When these two forces are equal, the balance arm and the spool in the pilot valve are in a neutral position — the complete unit is in a balanced position. Air is supplied to the pilot valve through port S, and controls the air flow through ports C1 and C2

**Assume an equilibrium position.**

An increased control pressure will deflect the diaphragm **1** down, compressing the feedback spring **3**. The balance arm **2** moves the spool **7** in the pilot valve **8** furnishing supply air to the actuator, while at the same time air is exhausted from actuator and is vented to atmosphere through the pilot valve and the OUT port . With the increased supply air, the actuator rotates (or moves linearly) moving the positioner spindle **6**. The spindle and cam **5** rotate, forcing the lower arm **4** upwards compressing the feedback spring **3**. This motion will continue until the two forces are equal and the unit is in an equilibrium position.

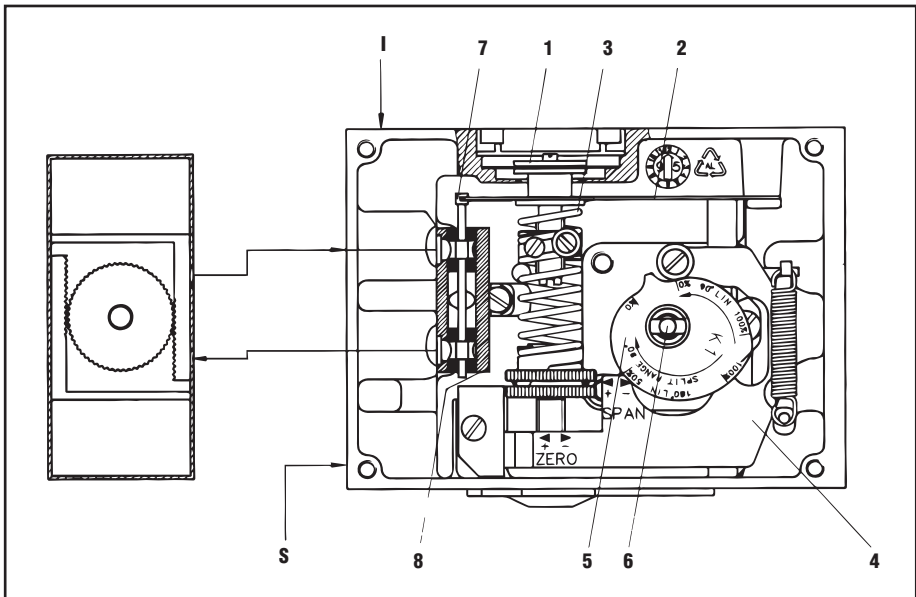



## 4. Installation

### Air requirements

Maximum supply pressure is 1 MPa (150 psi). Supply air shall be clean, dry and free from oil, water, moisture, foreign parts and debris.

The air shall be freeze-dried or similar to a dew point of at least 10°C (18°F) below lowest expected ambient temperature. The air shall comply with standard: DIN/ISO 8573-1-2001 3.2.3.

A <math>40\mu</math> filter/regulator is recommended to be installed as close to P4/P5/EP5 as possible to ensure proper supply air quality.

Before making pneumatic connections to the positioner, it is recommended that the supply air lines are opened up and allowed to vent for 2-3 minutes to clear any debris from the line. It is further recommended that a large paper bag is used to collect any oil or humidity that may be present in the line during this purging, direct the air flow into the bag. Should excessive amounts of oil and/or humidity be present at this stage, a review of the pneumatic system should be carried out and the problem corrected.

**Poor air quality is one of the major causes of premature failure of pneumatic equipment.**

### Installation

P4 and P5/EP5 mounts on to the actuator using either the ISO F05 holes 4 and a PMV ISO mounting kit or by using the optional mounting adaptor and screws 5 to mount P5 on to existing PMV mounting kits.

Proper alignment of the positioner spindle to the actuator shaft is very important since improper alignment can cause excessive wear and friction to the positioner.

### P5/EP5 only

The spindle/positioner shaft assembly allows for quick and simple spindle changes. To ensure the proper connection, the spindle 3 has a spring clip 2 that must be properly installed. A solid "click" should be felt when assembling the two pieces insuring that the two flats 1 are engaged into the positioner shaft groove.

The spindle can be removed, by inserting two screwdrivers under the two tapered surfaces of the spindle and bending carefully. When the spring clip releases the spindle will eject.

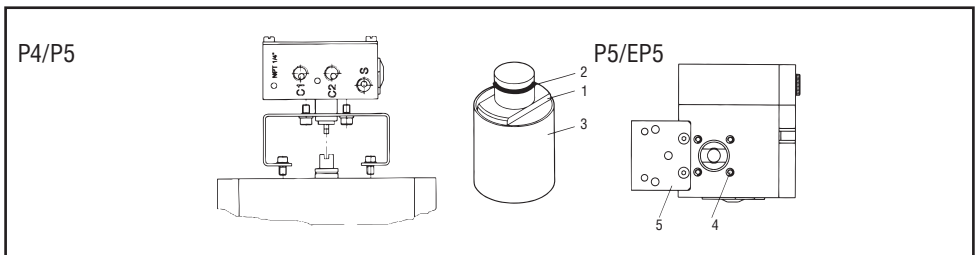

## 5. Connections

Air connections are tapped for 1/4" G or NPT male connectors and are clearly marked.

Gauge ports are for 1/8" G or NPT.

We recommend use of Loctite® 577 or similar user preferred for sealing.

Electrical connection on I/P unit accepts 1/2" NPT or PG 13,5 (M20) cable gland.

**Port I** Input instrument pneumatic signal 20-100kPa (3-15 psi)

**Port S** Supply air, maximum 1 MPa (150 psi) Minimum 0,15 MPa (21 psi) for EP5

**Port C1, C2** Actuator connections (0,2-1 MPa). C2 opening port.

For single acting operation plug port **C1** for increasing signal to open valve. Plug **C2** for decreasing (reverse) signal to open valve.

**OUT** Exhaust air port. **Do not block!** Exhaust filter optional.

**Port Ip** Gauge port for pneumatic input signal.

**Port I<sub>e</sub>** Input electric signal (4-20 mA) (On the I/P unit.)

**Port P** Gauge port for I/P unit output pressure ( On the I/P unit)

} P5/EP5 only

Ports **Ip, P, S, C1 and C2** are sealed with plugs. To install gauges, unscrew plugs and replace with gauges.

Port **OUT** is for venting the unit. All air from the positioner, actuator and I/P unit is vented to atmosphere through this port. **Do not block this port.** A high flow silencer or an exhaust pipe can be connected to this port to prevent foreign objects from entering and blocking the units exhaust. Connector in exhaust port must not have less than 9 mm (3/8") orifice.

When using gases other than air for supply — Please contact PMV.

On EP5 (P5 with I/P unit installed) I/P unit is supplied with air from port S. Port **I** is automatically sealed off and protected. No connection shall be made to this port. See pages 13 and 14 for more information.

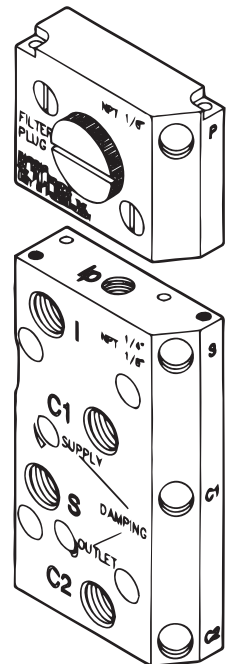

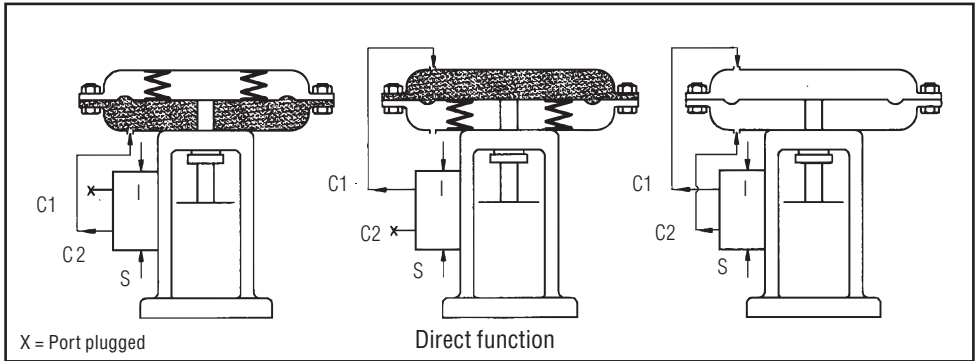

Direct function  
Air to open

Reverse function  
Air to close

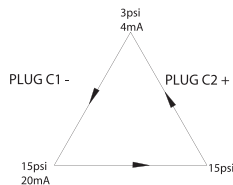
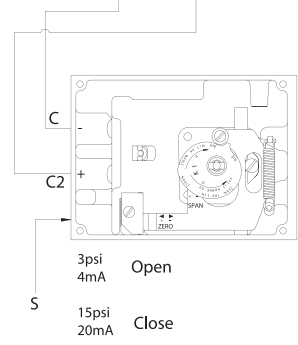
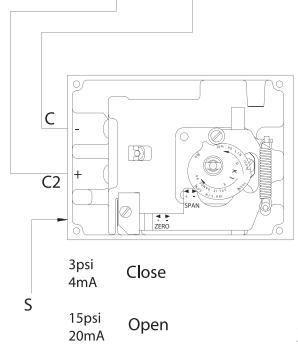
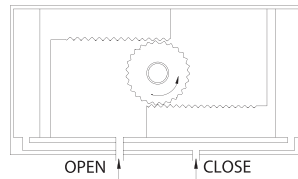
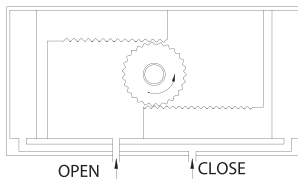
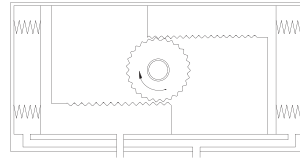
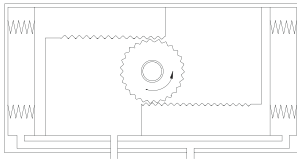

Signal/connection  
Spring return actuator

## 6. Cam adjustment

With the cover and indicator removed, loosen the screw **1** and turn the cam locking nut **2** counterclockwise until the cam loosens. Adjust the cam **3** as desired making sure that the ball bearing **4** always is riding on an active lobe on the cam. To secure the cam, make sure that screw **1** is backed out from the locking nut **2** then finger tighten the locking nut and tighten screw **1**. Install and adjust the indicator and reinstall cover.

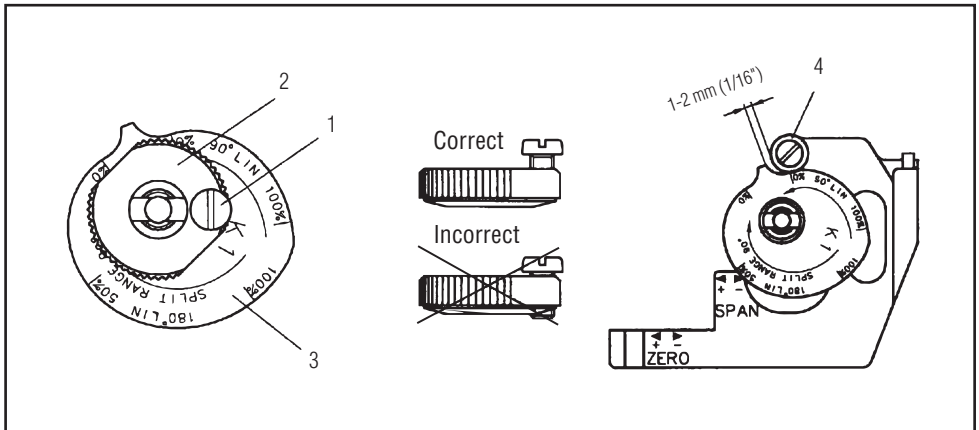

### Splined cam

As an option it is possible to configure the P5 with a splined cam. This design improves how the cam is engaged to the shaft and will improve performance. The splined cam will generate an increased safety in critical applications. See order code for more information how to order.

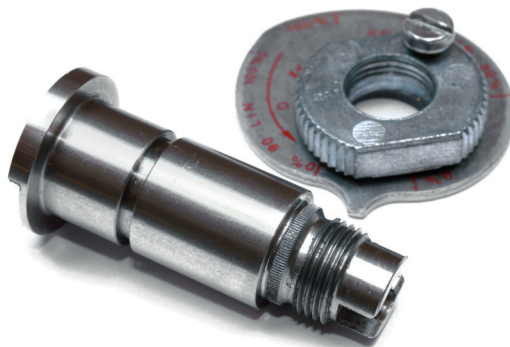

## 7. Calibration

P4/P5/EP5 is when shipped from PMV pre-calibrated for  $90 \pm 0,5$  deg rotation, (can also be 30, 45 or 60 deg, see installed cam). For most applications the valve closed position is more critical than valve open position, most attention should be paid at valve closed position. Always start calibration procedure by applying 0 % input signal, then adjusting zero. P4/P5/EP5 is calibrated by turning thumb wheels **1** & **4**.

Arrows on arm **5** indicate turning direction of thumb wheels.

< “+“ = Increase zero/span

> “-“ = Decrease zero/span

### Calibration procedure

Check cam seating, section 6 before starting calibration procedure.

1. Apply 0 % input signal (0% = 20 kPa/3 psi or 4 mA)
2. Wait for steady state.
3. Adjust zero by turning the silver (lower) thumb wheel **4** with finger or with screw- driver **7** from the outside.
4. Apply 100% input signal (100% = 100 kPa/ 15 psi or 20 mA)
5. Wait for steady state then memorize result.
6. Apply 0% input signal.
7. Adjust span if necessary. This is done by first loosening screw **2**, then turning the yellow (upper) thumb wheel **1** “+“ or “-“ and finally tightening screw **2**. Spring top must not be in contact with spring guide **3**.
8. Check zero and adjust if needed.
9. Repeat steps 2 to 8 until desired calibration is achieved.

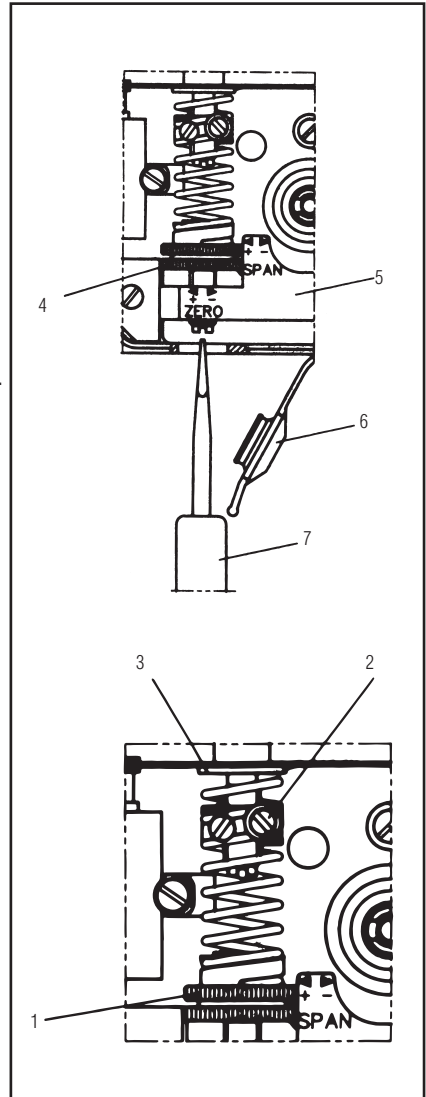

For calibration of APEX 7000 please see appendix A Calibration Procedure APEX 7000

## 8. Indicator adjustment

**P5/EP5:** To adjust the indicator, take off front cover and pull the indicator upwards until it comes off the Allen screw.

Before installing the indicator make sure that the Allen screw is tightened. Press the indicator on the screw and adjust it by rotating clockwise to desired position.

**P4:** Loose screw, adjust indicator, tighten screw.

## 9. Front cover and indicator cover

The front cover of P5 is secured to the pneumatic unit with four captured screws and sealed with an O-ring **1**. The O-ring can be looped over notches **2** in the front cover to allow for drainage. There are eight locations on the front cover where the O-ring can be looped. This O-ring system is common to the Pneumatic unit, I/P unit and Feedback unit in the PMV Valve Control System P5. This unique sealing system allows for complete sealing or draining of the units by changing the position of the O-ring.

The indicator cover **3** is O-ring sealed and secured by a bayonet coupling. The indicator cover is also used to secure the identification cover **4**.

To remove the indicator cover turn it slightly counterclockwise until it loosens. Identification cover and O-ring **5** are now removable.

When installing indicator cover and identification cover make sure that the O-ring is properly engaged.

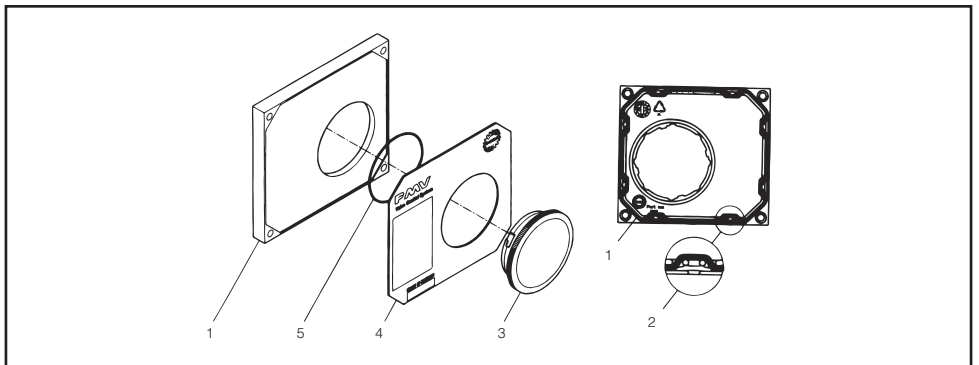

# 10. I/P Unit (EP5/APEX 7000)

**WARNING!**  
Units installed in hazardous areas must have proper approvals.

The I/P unit is mounted directly on top of the positioner unit.

No external air supply is needed since the I/P unit is supplied with air from the positioner unit.

Port **I** on the positioner unit will be plugged when the I/P unit and the appropriate gauge block gasket installed. The I/P unit accepts a 4-20 mA input signal.

The I/P unit is equipped with a built in 30 micron filter (Fig 4).

**Caution:** Do not operate the unit without filter and filterplug installed.

Ensure that wiring between I/P and terminals are properly seated in rubber clamp.

Do not unscrew filterplug when the positioner is pressurized.

Span and Zero for the I/P converter is factory set and can not be adjusted

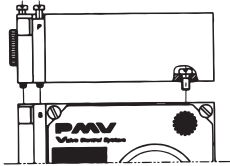

Fig 1



Fig 2

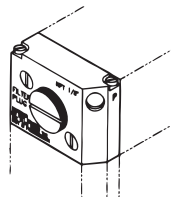

Fig 4

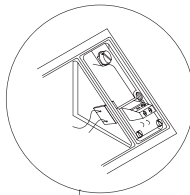

Fig 3

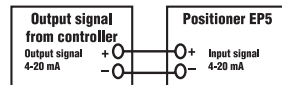

Fig 5

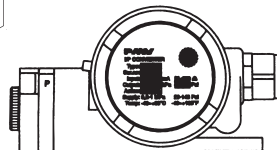
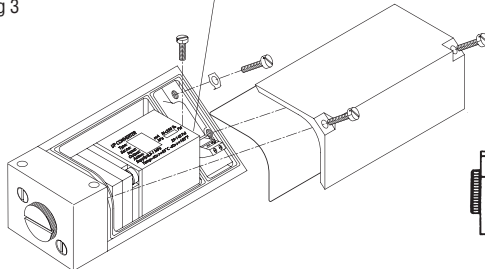

Fig 6

# 11. How to mount the I/P Unit to the positioner unit (P5/EP5)

Switch off supply air and disconnect input signal – port **I**.

Loosen screws **3** and remove connection block **1**, the gauge or plug from port **Ip**, the fitting from port **I** and existing gasket **4**. Carefully install gasket **6** supplied together with I/P unit. When correct installed port **I** will be blocked by the gasket.

Make sure that relief valve spring **5** is installed properly. Install the connection block **1** to the positioner unit **2**.

Remove cover on I/P unit.

Install the I/P unit to the top of the Positioner unit, making sure that the four O-rings are present and properly seated. Tighten the unit with the three screws. (See fig. 1 and 2 page 16) Screw **1** first, screw **2** last.

**WARNING!**  
Units installed in hazardous areas must have proper approvals.

Connect input signal cable to port **I<sub>e</sub>** and tighten the cable gland (see fig 5 on page 16). Adjust the O-ring on the I/P Unit housing to desired position - sealed or drained. (See fig 3 on page 16 or section 9 on page 14).

A gauge indicating output signal from the I/P converter can be installed in port **P**. Make sure that the filter plug is tightened before supply air is switched on (Fig 4 on page 16).

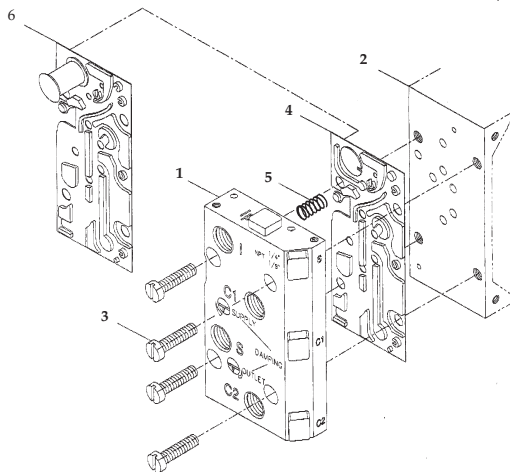



## 12. Maintenance

### Pilot valve

To remove the pilot valve for cleaning or inspection, remove the screw **1** and carefully lift out the complete assembly **2**. Gently remove the spool **3** from the block and clean the parts, using methylate cleaner or similar. Blow the parts dry with compressed air. Install the spool into the pilot valve housing, place it on a flat surface, then lift it carefully in one end. Before reaching 20 deg angle the spool should slide by itself.

Should the parts show signs of wear, a new assembly is recommended. Mixing spool valves and valve bodies may result in very high bleed rates and poor performance. Check the O-rings, then secure and install the pilot valve assembly into positioner unit, press it towards the positioner housing wall and secure it with screw **1**. Make sure that the leaf spring **4** on the balance arm **5** is properly fitted in the groove on the spool **6**. Check again to insure smooth operation of the assembly.

To maintain original factory performance specifications, use only spool valve assemblies supplied by PMV.

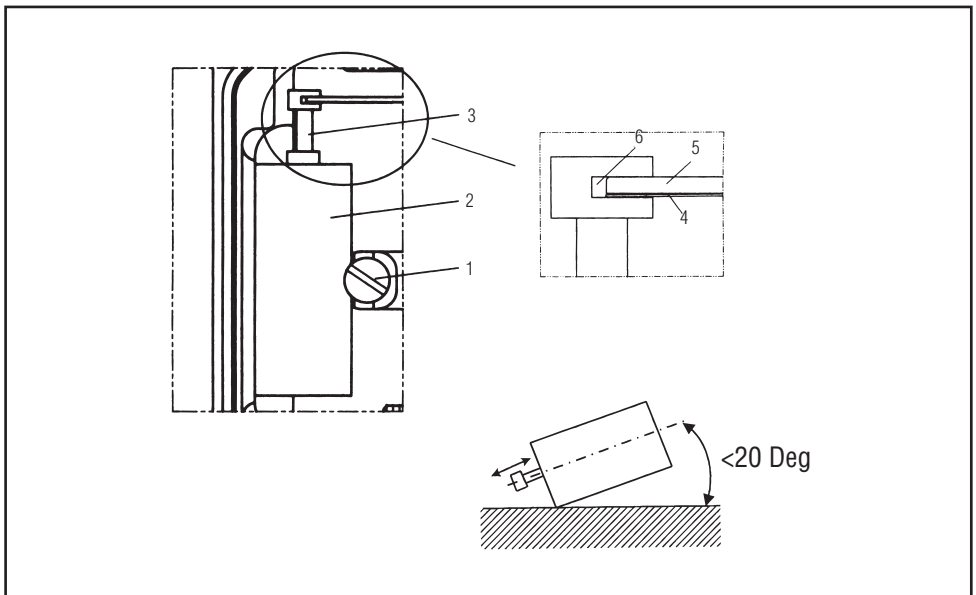

**Diaphragm**

If P5 is equipped with I/P unit (EP5), the I/P unit must be removed to access the diaphragm. When installing the diaphragm make sure to place one washer on each side of the diaphragm. Put some Loctite 577 on the thread, install the screw **3** and tighten.

Make sure the diaphragm is centered.

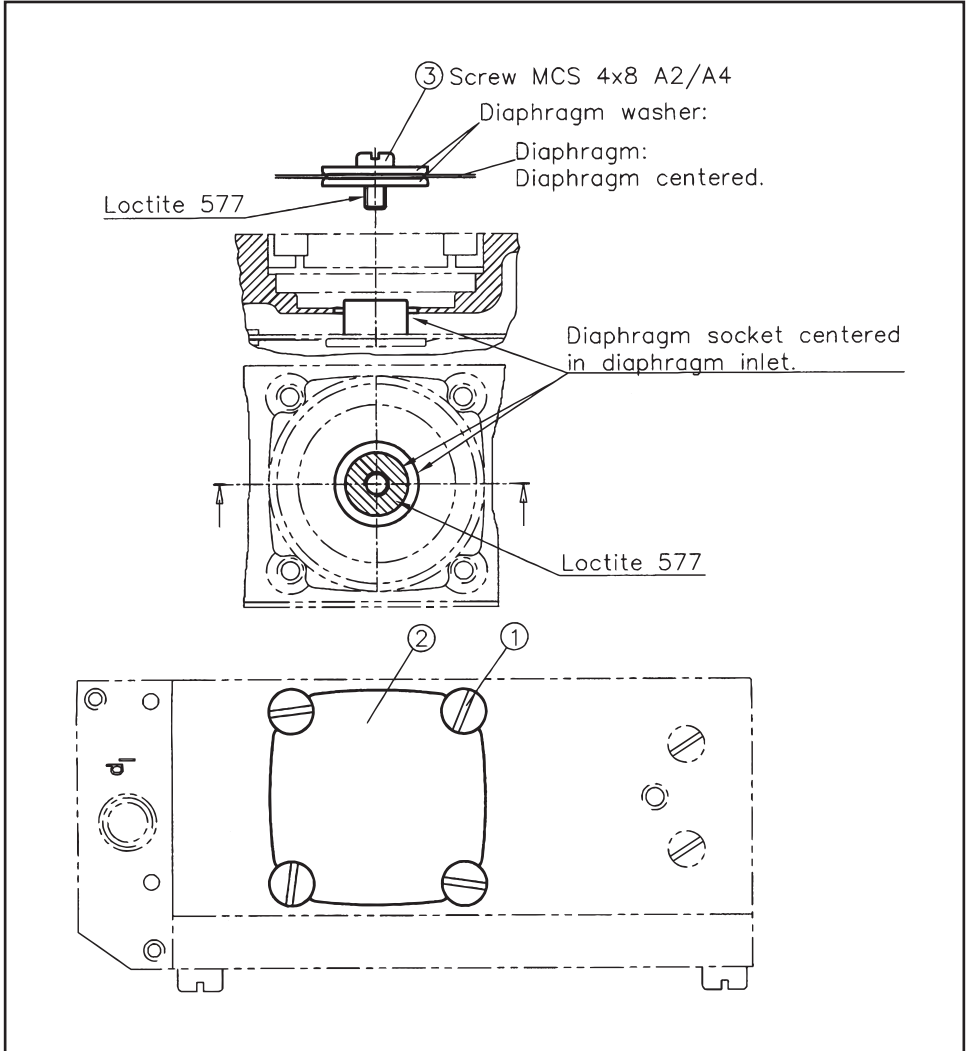

Check the O-ring for the diaphragm cover **2**, install the O-ring into the positioner housing, then install cover **2**. Secure crosswise with screws **1**, first turn loosely. Torque shall be 4,5 Nm (40 in-lbs).

**Feedback spring**

Once the front cover and indicator are removed, the feedback spring can be easily accessed.

Hold the spring **1** from the top, pull down and out.

When installing, hold the assembly at the top, guide the lower part to position on the zero screw, then press down until it fits easily under the balance arm **2**. Make sure that the assembly is aligned properly against the lower arm and the notch is engaged in the tab on the balance arm **2**.

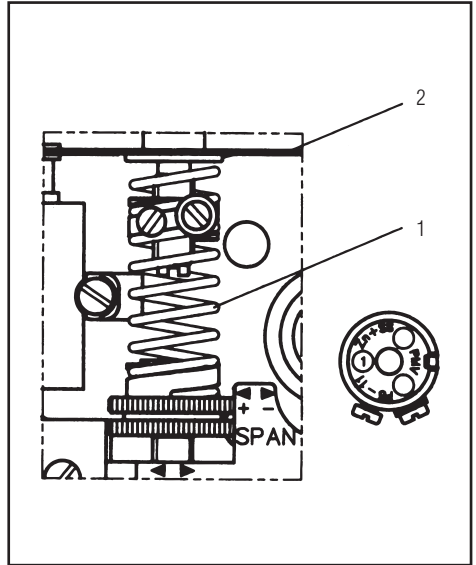

**Balance arm**

The balance arm **3** can only be removed after I/P unit, diaphragm and feedback spring have been removed. (See sections above and on page 16, 18 and 19).

Loosen the screws **3** and the balance arm can be removed.

When installing the balance arm make sure that the leafspring **4** on the underside of the balance arm **5** is properly engaged into the groove **6** of the spool in the pilot valve. Tighten the two screws **3** holding the balance arm to the positioner.

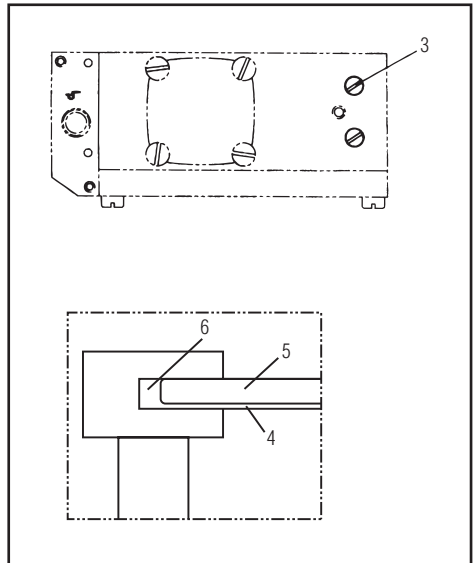

**Lower arm**

Once the front cover is removed, the lower arm can be easily accessed.

Remove the indicator, feedback spring and the cam.

Loosen screw **2** and remove twist stop **1**.

Remove screw **3**, lower arm **4**, rod **5** and spring **6**.

Check rod and lower arm for wear, replace if necessary. Clean the rod and install it in the lower arm. The lower arm should move easily and smoothly.

Install the lower arm and rod assembly into the positioner housing, making sure that the spring **6** is attached properly to the lower arm and positioner housing.

Secure the lower arm and rod assembly with the screw **3**.

Check again that the lower arm moves smoothly.

Apply a small amount of grease on the small tongue on the lower arm, then install and secure the twist stop.

Install cam, feedback spring, indicator and front cover.

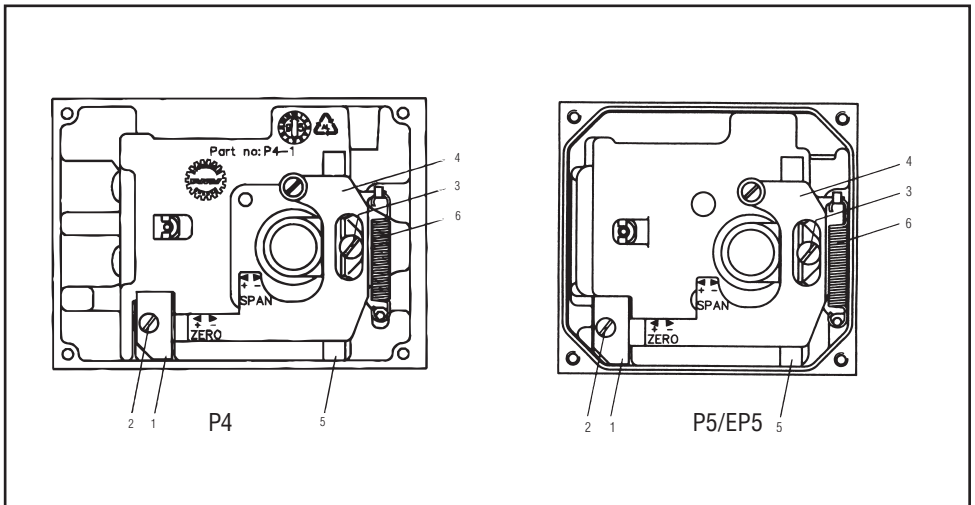

### O-rings

With time and use, O-rings can become brittle. This can cause poor operation and even failure of the positioner.

Always check O-rings when performing any work on the positioner and replace bad O-rings.

A thin layer of silicon grease applied on the NBR (Black) O-rings prolongs their life. On Q (red) O-rings, use a non silicon based grease.

### Filter plug (EP5)

**Caution!**

Do not operate the unit without filter and filter plug installed. Do not attempt to unscrew filter plug while positioner is pressurized.

EP5 is equipped with a built in secondary filter located on the side of the I/P unit.

For replacement or inspection, make sure that positioner unit is not pressurized, then unscrew filter plug **1**. Remove filter **3** and install a new into the filter plug . Check condition of O-ring **2** and filter compartment. If moisture is found, check upstream filters/oil-water separators.

Moisture can cause I/P failure.

Reinstall filter plug.

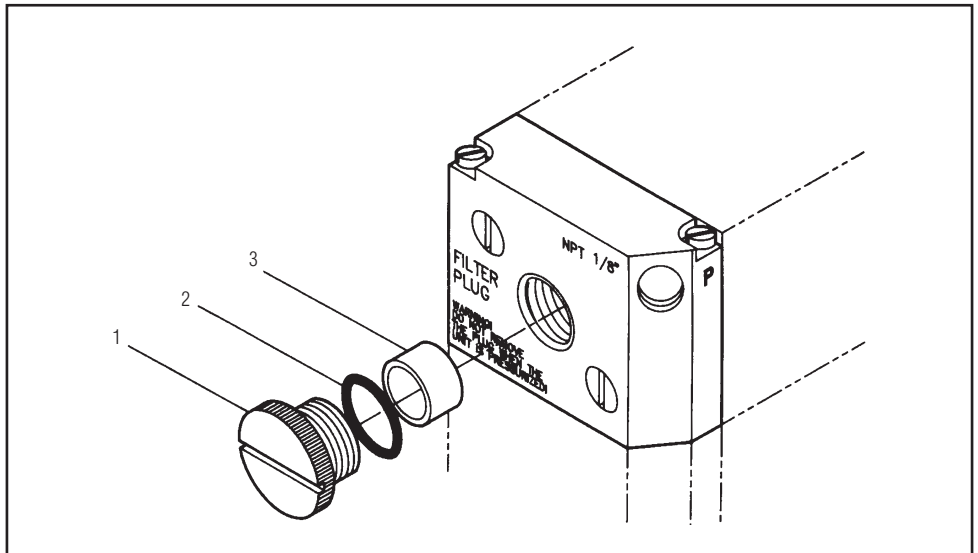

## 13. Feedback unit (P5 or EP5)

See feedback module instructions for connections and calibration.

The P5 or EP5, Valve Control System, can easily be equipped with a Feedback unit, model F5. This unit will mount directly on top of the Pneumatic positioner replacing the positioner front cover. The O-ring located on the bottom of the Feedback unit, F5, will provide the same sealing or draining capabilities as the front cover. The indicator and front cover from the positioner unit can then be installed on to the Feedback unit.

**WARNING!**

Units installed in hazardous locations must have proper approvals.

Installing the feedback unit.

- Remove the front cover, indicator, and Allen head screw from the top of the positioner spindle.
- Install the drive coupling **4** and adjust the O-ring seal on the bottom in either sealed or draining position. (See section 6, page 10).
- Install the Feedback unit **9** on top of the Positioner unit, making sure the coupling is properly engaged before tightening the four screws **5**.
- Make electrical connections and tighten cable glands. (See F5 manual for details).
- Adjust cams and/or potentiometer to desired position.
- Install the indicator and front cover.

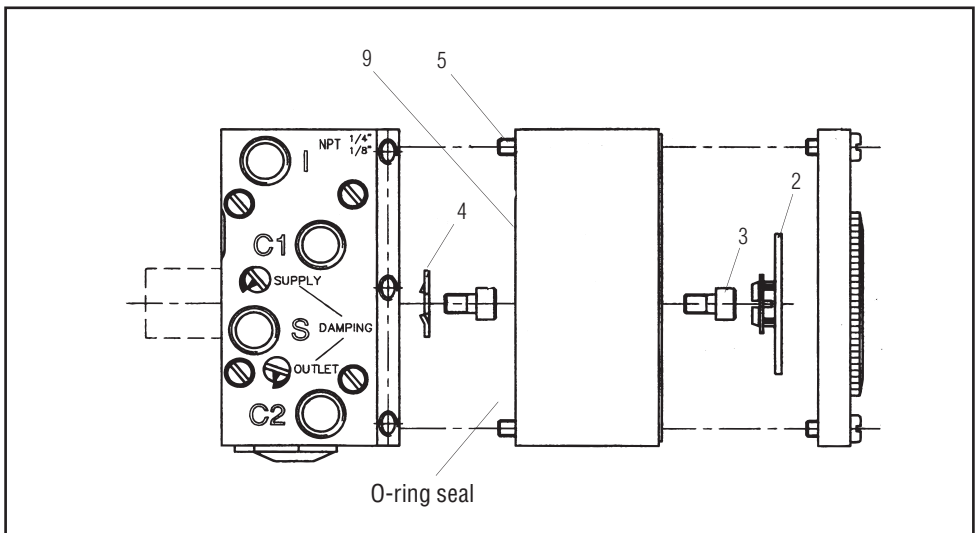

## 14. Trouble shooting

---

**Note:** All PMV-Positioners are serialized. Please note down, and provide the serial number when contacting the factory for trouble shooting or service.

Signal change has no effect on the actuator position.

- Check indicator and screw.
- Check air supply to positioner and tubing to the actuator.
- Check input signal to positioner.
- Check diaphragm for damage or leakage.
- Check pilot valve function.
- Check cam for correct setting.
- Check I/P output

Signal change results in actuator running to end positions.

- Check coupling between positioner and actuator.
- Check cam position and locking screw.
- Check input signal.
- Inaccurate positioning.
- Dirty or worn pilot valve.
- Defective or leaking diaphragm.
- Input signal fluctuates.
- Incorrect sizing of actuator.
- Valve/actuator "stiction".
- High valve/actuator breakaway torque.
- Loose cam.

## 15. Technical data

### P4

Input Signal	20-100 kPa/3-15 Psi (6-30 Psi optional)
Linearity (%)*	0,7
Hysteresis+deadband (%)*	0,8
Repeatability (%)*	0,5
Pressure gain at load 20% (%/%)	20 %/ % ISA 75.13 1989 (kPa/kPa) 300
Air consumption at supply pressure: 0,6 MPa/87 Psi	8 nl/min (0.31 SCFM)
Air delivery at supply pressure:	
0,2 MPa/29 Psi	140 nl/min (5.46 SCFM)
0,4 MPa/58 Psi	245 nl/min (9.55 SCFM)
0,6 MPa/87 Psi	350 nl/min (13.65) SCFM
Supply Pressure	Max 1 MPa/150 Psi
Temperature range	-20°C to +85°C (-4°F to 185°F)
Connector threads	1/4" NPT
Weight std. 0,9 kg/2 lbs	

\* % of full scale.



	<b>P5</b>	<b>EP5</b>
Input Signal	20-100 kPa/3-15 Psi (6-30 optional)	4-20 mA
Linearity	≤ 0,5% *	≤ 0,5% *
Hysteresis	≤ 0,75% *	≤ 0,5% *
Repeatability	≤ 0,5% *	≤ 0,5% *
Gain	(pressure 600 kPa/87 Psi) 1 000 (kPa/kPa) Min 66%/ % ISA S75.13	
Air consumption at Supply pressure:		
0,2 MPa/29 Psi	5,4 nl/min 0.19 SCFM	6,1 nl/min 0.22 SCFM
0,4 MPa/58 Psi	12,3 nl/min 0.43 SCFM	13,6 nl/min 0.48 SCFM
0,6 MPa/87 Psi	20 nl/min 0.71 SCFM	22 nl/min 0.78 SCFM
0,8 MPa/116 Psi	27,8 nl/min 0.98 SCFM	30,5 nl/min 1.08 SCFM
1 MPa/145 Psi	35,7 nl/min 1.26 SCFM	39 nl/min 1.38 SCFM
Air delivery at Supply Pressure:		
0,2 MPa/29 Psi	200 nl/min 6.9 SCFM	200 nl/min 6.9 SCFM
0,4 MPa/58 Psi	370 nl/min 12.8 SCFM	370 nl/min 12.8 SCFM
0,6 MPa/87 Psi	540 nl/min 18.8 SCFM	540 nl/min 18.8 SCFM
0,8 MPa/116 Psi	710 nl/min 24.7 SCFM	710 nl/min 24.7 SCFM
1 MPa/145 Psi	880 nl/min 30.6 SCFM	880 nl/min 30.6 SCFM
Supply Pressure Max 1 MPa/150 Psi		0,15-1 MPa/21,8-150 Psi
Temperature range	-20°C to -85°C (-4°F to 185°F)	-20°C to -85°C (-4°F to 185°F)
Connector threads	¼" NPT or G	¼" NPT or G
Gauge threads	1/8" NPT or G	1/8" NPT or G
Weight std.	1,1 kg/2.4 lbs	1,5 kg/3.4 lbs
Weight with gauges	1,3 kg/2.9 lbs	1,8 kg/3.9 lbs
Ingress protection		IP 66/NEMA 4

\* % of full scale.

(The information in this manual is subject to change without notice.)

**Dimensional drawing (P4)**

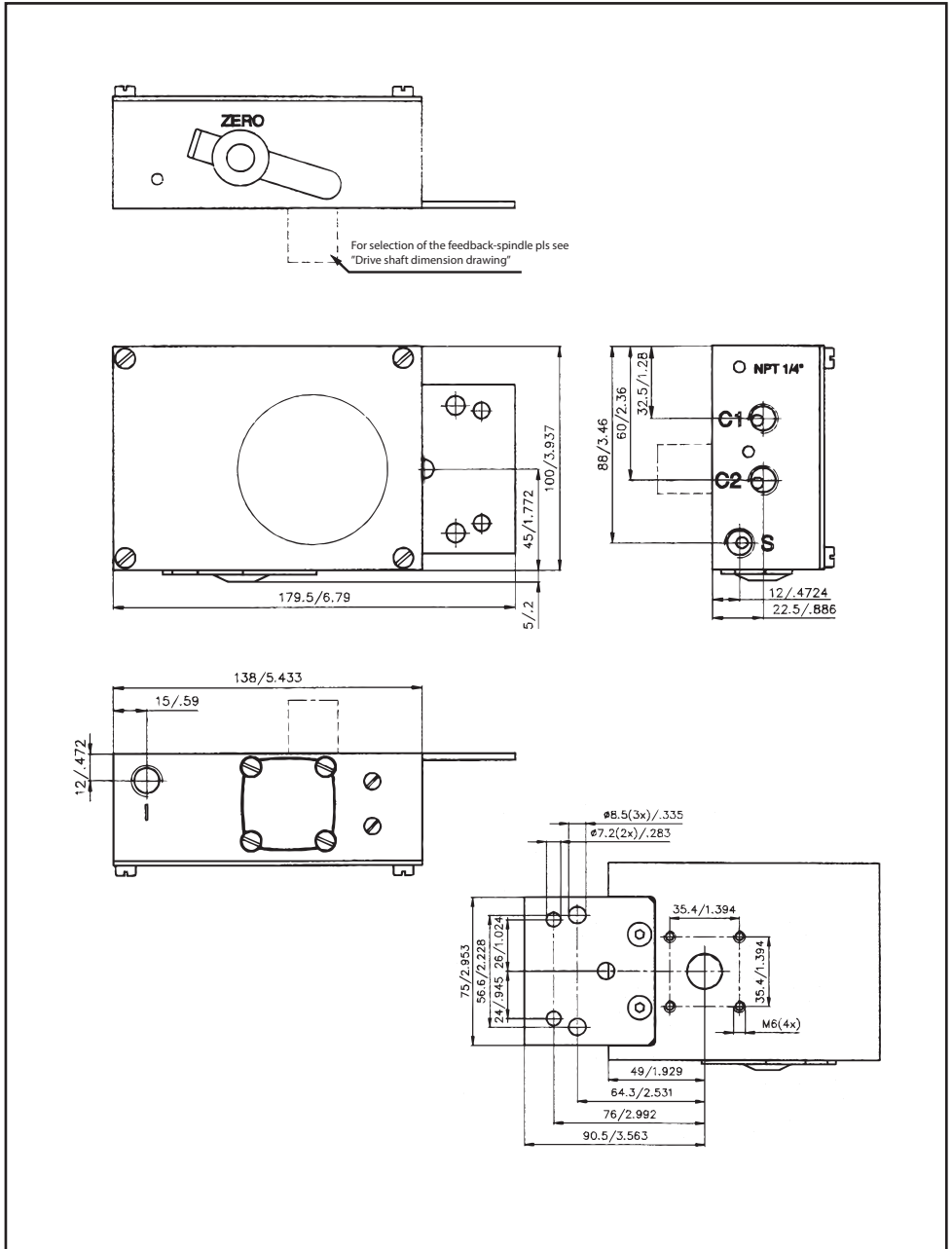

# 16. Spare parts

## P4

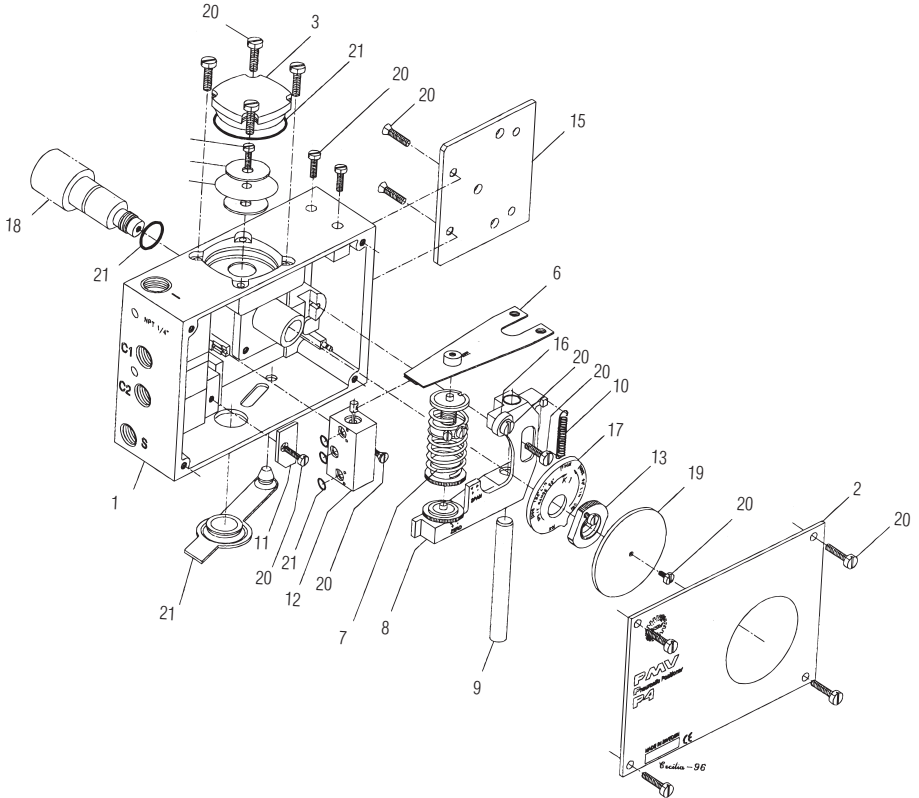

No	Part no	Qty	Description	Remarks
1.		1	Housing 1 N/A	
2.	P4-xx	1	Front cover	
3.	P4-7	1	Diaphragm cover incl. O-ring	
4.	P5-8	1	Diaphragm	
5.	P5-9	2	Diaphragm washer	
6.	P5-10	1	Balance arm	
7.	P5-AS13/315	1	Feedback spring 3-15 Psi assembly	
7.	P5-AS13/630	1	Feedback spring 6-30 Psi assembly	(Green)
8.	P4-AS18	1	Lower arm assembly	
9.	P5-19	1	Rod	
10.	P5-20	1	Spring	
11.	P5-24	1	Twist stop	
12.	P4-AS25	1	Pilot valve incl. O-rings	
13.	P5-27	1	Cam locking nut incl. screw	
15.	P5-31	1	Mounting adapter incl. screws	
16.	P5-32	1	Ball bearing	
17.	P5-K1	1	Cam K1 90°/180° Linear 0-100%, split range 0-50-100% 1	
17.	P5-Kxx	1	Cam special, K2-K10 (ConsultPMV)	
18.	P4-	1	Cxx Spindle (Consult PMV)	
19.	12013	1	Indicator Arrow type 1	
20.	P4-SCREW			Screw set Set
21.	P4-SEAL NBR		Seal and O-ring set NBR, Nitrile rubber. Set (4, 21)	

**P5/EP5**

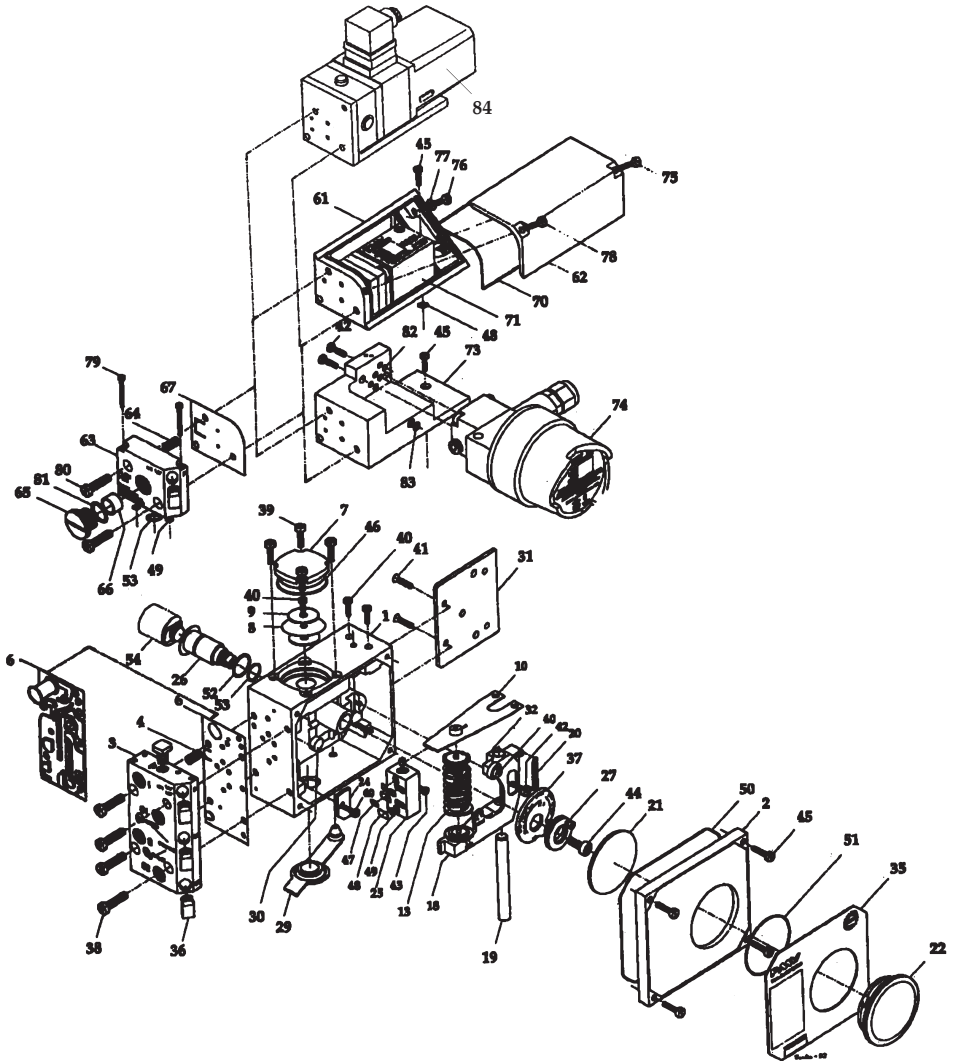

Pos	Part no	Qty	Description
1		1	Housing
2	P5-2	1	Front Cover incl. O-ring
3	P5-AS3N	1	Connecting block NPT 1/4" assembly
3	P5-AS3G	1	Connecting block G 1/4" assembly
4	P5-4	1	Relief valve spring
6	P5-6P	1	Gasket for P5
6	P5-6EP	1	Gasket for EP5
7	P5-7	1	Diaphragm cover incl. O-ring
8	P5-8	1	Diaphragm
9	P5-9	2	Diaphragm washer
10	P5-1	1	Balance arm
13	P5-AS13/315	1	Feedback spring 3-15 psi assembly
13	P5-AS13/630	1	Feedback spring 6-30 psi assembly
18	P5-18	1	Lower arm assembly
19	P5-19	1	Rod
20	P5-20	1	Spring
21	P5-21A	1	Indicator Arrow
21	P5-21F	1	Indicator Flag
21	P5-21P	1	Indicator Pointer
22	P5-22T	1	Indicator cover Transparent incl. O-ring
22	P5-22F	1	Indicator cover Flag incl. O-ring
22	P5-22B	1	Indicator cover Blind incl. O-ring
24	P5-24	1	Twist stop
25	P5-25	1	Pilot valve incl. O-rings
26	P5-26	1	Shaft incl. O-rings, screw
27	P5-27	1	Cam locking nut incl. screw
29	P5-29	1	Zero cover
30	P5-30	1	Cover
31	P5-31	1	Mounting adapter, incl screws
32	P5-32	1	Ball bearing
35	P5-xx/xx	1	Identification cover
36	12047N	4	Plug NPT 1/8"
36	12047G	4	Plug 1/8" G
37	P5-Kxx	1	Cam
38-45	P5-Screws	1	Screw set P5/EP5
75-80			
46-53	P5-Seal NBR	1	O-ring set P5/EP5 Nitrile, NBR
81-83, 6, 67, 70			
46-53	P5-Seal Q	1	O-ring set P5/EP5 Silicone, Q
81-83, 6, 67, 70			
54	P5-Sxx	1	Spindle adaptor

P5/EP5

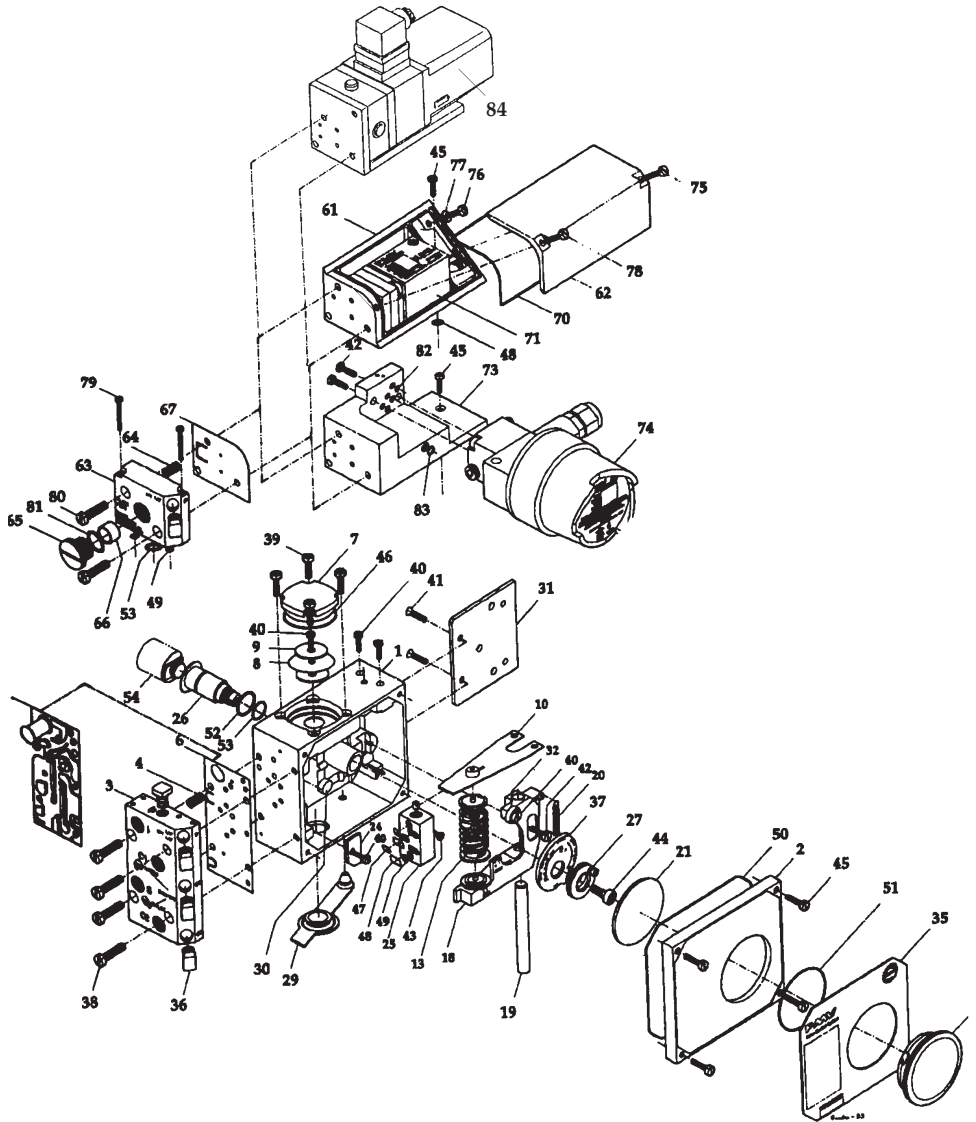

Pos	Part no	Qty	Description
61		1	I/P box
62	E5-2	1	I/P cover incl. screws
63	E5-AS3N	1	I/P nose NPT 1/4" assembly
63	E5-AS3G	1	I/P nose G 1/4" assembly
64	P5-4	1	Relief valve spring
65	E5-5	1	Filter plug incl. Filter 66, O-ring, 81
66	E5-6	1	Filters (5 per package)
67	E5-7	1	Gasket I/P
71	E5-STD	1	I/P converter
73	E5 N-AS 11	1	Mounting bracket Round I/P
	E5 G-AS 11		incl. screws, O-rings, I/P Nose
74	FU-STD	1	Enclosure incl. I/P converter Std.
74	E5-EX/EU	1	Enclosure incl. I/P converter, flameproof Cenelec
74	E5-EX/US	1	Enclosure incl. I/P converter, Explosion proof FM, CSA
84	E5-FS	1	I/P converter fail in last position incl. bracket



# Appendix A

---



## Calibration Procedure APEX 7000:

1. Apply 0% input signal (0% = 20 kPa, 3 psi, or 4 mA).
2. Wait for steady state. It is important to wait for steady state. On very large actuators, it can take minutes to establish.
3. Loosen locking screw **A** about 1 turn, if it is looser, you risk introducing unwanted movement.
4. Adjust "ZERO" position using thumbwheel **B**
5. Apply 100% input signal (100% = 100 kPa, 15 psi, or 20 mA).
6. Wait for steady state.
7. With a screw drive, adjust the "SPAN" setting by turning screw **C**, while doing so, keep the zero screw **B** in position by applying pressure with your thumb.
8. Lock the calibration mechanism in place by tightening locking screw **A**
9. Apply 0% signal and verify zero position.

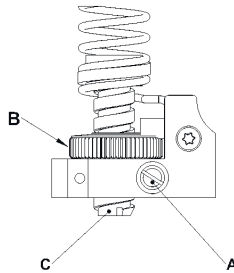

## FCD PMENIM0006-00-A5 12/18

To find your local Flowserve representative:

To find your local Flowserve representative please use the Sales Locator

System found at [www.flowserve.com](http://www.flowserve.com)

Flowserve Corporation has established industry leadership in the design and manufacture of its products. When properly selected, this Flowserve product is designed to perform its intended function safely during its useful life. However, the purchaser or user of Flowserve products should be aware that Flowserve products might be used in numerous applications under a wide variety of industrial service conditions. Although Flowserve can provide general guidelines, it cannot provide specific data and warnings for all possible applications. The purchaser/user must therefore assume the ultimate responsibility for the proper sizing and selection, installation, operation, and maintenance of Flowserve products. The purchaser/user should read and understand the (D3 Digital Positioner User Instructions) instructions included with the product, and train its employees and contractors in the safe use of Flowserve products in connection with the specific application.

While the information and specifications contained in this literature are believed to be accurate, they are supplied for informative purposes only and should not be considered certified or as a guarantee of satisfactory results by reliance thereon. Nothing contained herein is to be construed as a warranty or guarantee, express or implied, regarding any matter with respect to this product. Because Flowserve is continually improving and upgrading its product design, the specifications, dimensions and information contained herein are subject to change without notice. Should any question arise concerning these provisions, the purchaser/user should contact Flowserve Corporation at any one of its worldwide operations or offices.

For more information about Flowserve Corporation, contact [www.flowserve.com](http://www.flowserve.com) or call USA 1-800-225-6989.

© May 2018, Flowserve Corporation, Irving, Texas

### PMV Automation AB

Korta Gatan 9  
SE-171 54 SOLNA  
SWEDEN  
Phone: +46 (0)8-555 106 00  
E-mail: [infopmv@flowserve.com](mailto:infopmv@flowserve.com)

### PMV USA

14219 Westfair West Drive  
Houston, TX 77041, USA  
Phone: +1 281 671 9209  
Fax: +1 281 671 9268  
E-mail: [pmvsales@flowserve.com](mailto:pmvsales@flowserve.com)

### Flowserve Flow Control

Burrell Road, Haywards Heath  
West Sussex RH16 1TL  
Phone: +44(0)1444 314400  
E-mail: [pmvuksales@flowserve.com](mailto:pmvuksales@flowserve.com)

### Flowserve Flow Control Benelux

Rechtzaad 17  
4703 RC Roosendaal  
THE NETHERLANDS  
Phone: +31 (0) 30 6771946  
Fax: +27 (0) 30 6772471  
E-mail: [fbinfo@flowserve.com](mailto:fbinfo@flowserve.com)

### Flowserve Flow Control GmbH

Rudolf-Plank Strasse 2  
D-76275 Ettlingen  
GERMANY  
Phone: +49 (0) 7243 103 0  
Fax: +49 (0) 7243 103 222  
E-mail: [argus@flowserve.com](mailto:argus@flowserve.com)

### Flowserve Corporation

No. 35, Baiyu Road  
Suzhou Industrial Park  
Suzhou 215021, Jiangsu Province,  
PRC  
Phone: +86-512-6288-1688  
Fax: +86-512-6288-8737

### Flowserve (China)

585, Hanwei Plaza  
7 Guanghau Road  
Beijing, China 100004  
Phone: +86 10 6561 1900

### Flowserve Pte Ltd

No. 12 Tuas Avenue 20  
Singapore 638824  
Phone: +65 6879 8900  
Fax: +65 6862 4940

### Flowserve do Brasil Ltda

Rua Tocantins, 128 - Bairro Nova Gerti  
São Caetano do Sul,  
São Paulo 09580-130 Brazil  
Phone: +5511 4231 6300  
Fax: +5511 4231 6329 - 423